



# HYPNOTIC™

Audio for Mind, Body & Soul



2024-2025 PRODUCT GUIDE



**FEATURES:**

- Class D circuitry
- Audiophile grade components
- Variable high pass - band pass - low pass crossover
- Ultra high efficiency mosfet design
- Heat management system
- Selectable input gain range
- Double Sided PCB
- 2Ω stereo / 4Ω Bridged capability

MODEL #	DESCRIPTION	4 Ω @ 14.4 V	2 Ω @ 14.4 V	4 Ω Bridged @ 14.4 V	CAPABILITY	M CARTON
HX800.4	4 Channel Class D Amplifier	4 x 100 Watts	4 x 200 Watts	2 x 200 Watts	2 Ω Stereo	5
HX1200.4	4 Channel Class D Amplifier	4 x 150 Watts	4 x 300 Watts	2 x 300 Watts	2 Ω Stereo	5
MODEL #	DESCRIPTION	4 Ω @ 14.4 V	2 Ω @ 14.4 V	2 Ω @ 14.4 V (CH.5)	CAPABILITY	M CARTON
HX2000.5D	5 Channel Class D Amplifier	4 x 100 Watts	4 x 200 Watts	1 x 600 Watts	2 Ω Stereo	5

MODELS:	HX800.4	HX1200.4
• Ch 1-2 / 3-4 High Pass Crossover:	20Hz - 5KHz	20Hz - 5KHz
• Ch 1-2 / 3-4 Low Pass Crossover:	50Hz - 5KHz	50Hz - 5KHz

MODELS:	HX2000.5D
• Ch 1-2 / 3 - 4 High Pass Xover:	40Hz - 300Hz
• Ch 5 Low Pass Crossover:	40Hz - 300Hz

SPECIFICATIONS:	
• X-Over Slope:	12 dB
• Bass Boost @ 45Hz:	0 - 12dB
• Input Sensitivity:	250mV - 6V
• Signal to Noise Ratio:	>92dB
• Frequency Response	10Hz - 22KHz
• Subsonic Filter:	0 - 25 Hz



**HX2000.5D**  
REMOTE BASS CONTROL INCLUDED

Dimensions	L	H	W
HX800.4	7" / 178mm	2" / 51mm	5.50" / 140mm
HX1200.4	7.95" / 202mm	2" / 51mm	5.50" / 140mm
HX2000.5D	9.75" / 248mm	2" / 51mm	5.50" / 140mm



**NEW 2024**

## FEATURES:

- Class D Monoblock Amplifier
- PWM Mosfet power supply
- RCA line level Stereo inputs
- Double Sided PCB
- Heat management system
- Selectable input gain range
- Remote Bass Control Included



MODEL #	DESCRIPTION	1 Ω @ 14.4 V	2 Ω @ 14.4 V	CAPABILITY	M CARTON
HX1200.1D	Class D Monoblock Amplifier	1 x 600 Watts	1 x 300 Watts	1 Ω Stereo	5
HX2400.1D	Class D Monoblock Amplifier	1 x 1200 Watts	1 x 600 Watts	1 Ω Stereo	5
HX3600.1D	Class D Monoblock Amplifier	1 x 1800 Watts	1 x 900 Watts	1 Ω Stereo	5

## SPECIFICATIONS:

- Bass Boost @ 45Hz: 0 - 12dB
- Input Sensitivity: 250mV - 6V
- Signal to Noise Ratio: >90 - 95dB
- Frequency Response: 10Hz - 250Hz

MODELS:	HX1200.1D	HX2400.1D	HX3600.1D
• Low Pass Filter:	40Hz - 300Hz	40Hz - 300Hz	40Hz - 300Hz
• Subsonic Filter:	0Hz - 25Hz	0Hz - 25Hz	0Hz - 25Hz

Dimensions	L	H	W
<b>HX1200.1D</b>	7.50" / 191mm	2" / 51mm	5.50" / 140mm
<b>HX2400.1D</b>	9.45" / 240mm	2" / 51mm	5.50" / 140mm
<b>HX3600.1D</b>	10.20" / 260mm	2" / 51mm	5.50" / 140mm



**HX1200.1D, 2400.1D, 3600.1D**

**REMOTE BASS CONTROL INCLUDED**



### FEATURES:

- Class AB Circuitry
- 2 Ohm Load Stereo Capability
- Audiophile Grade Components
- Variable High Pass and Low Pass X-Over
- High Efficiency Mosfet Design
- Heat Management System

Hypnotic Illuminated Logo

### Active Hp/Lp Crossovers



### Bridgeable Outputs



Large Input Connectors

MODEL #	DESCRIPTION	4 Ω @ 14.4 V	2 Ω @ 14.4 V	4 Ω Bridged @ 14.4 V	CAPABILITY	M CARTON
HYP1004	4 Channel Class A/B Amplifier	4 x 100 Watts	4 x 200 Watts	2 x 400 Watts	2 Ω Stereo	4
HYP1254	4 Channel Class A/B Amplifier	4 x 125 Watts	4 x 250 Watts	2 x 500 Watts	2 Ω Stereo	4
HYP1504	4 Channel Class A/B Amplifier	4 x 150 Watts	4 x 300 Watts	2 x 600 Watts	2 Ω Stereo	4
HYP1252	2 Channel Class A/B Amplifier	2 x 125 Watts	2 x 250 Watts	1 x 500 Watts	2 Ω Stereo	5

MODELS:	HYP1004 / HYP1254	HYP1504
• Ch 1-2/ 3-4 High Pass Xover:	40Hz - 400Hz	50Hz - 500Hz
• Ch 3-4 Low Pass Crossover:	50Hz - 400Hz	

MODELS:	HYP1252
• Ch 1-2 High Pass Xover:	50Hz - 250Hz
• Ch 1-2 Low Pass Crossover:	50Hz - 250Hz

SPECIFICATIONS:	
• X-Over Slope:	12 dB
• Bass Boost @ 45Hz:	0 - 6 - 12dB
• Input Sensitivity:	285mV - 6V
• Signal to Noise Ratio:	>90dB
• THD at Rated Power:	<0.5%

### Dimensions

	L	H	W
HYP1004	9.84" / 250mm	2.20" / 56mm	6.10" / 155mm
HYP1254	10.62" / 270mm	2.20" / 56mm	6.10" / 155mm
HYP1504	13.77" / 350mm	2.20" / 56mm	6.10" / 155mm
HYP1252	7.04" / 179mm	2.20" / 56mm	6.10" / 155mm





Hypnotic Illuminated Logo

### FEATURES:

- Class AB Monoblock Amplifier (HYP1200D)
- Class D Mono Block Amplifier
- 1 Ohm Stable
- 2 Ohm Stable Capability (HYP1200D)
- PWM Mosfet Power Supply
- RCA Line Level Stereo Inputs
- 12dB / Variable Low Pass Crossover
- Variable Subsonic Filter
- Selectable Bass Boost @ 45 Hz
- Thermal Protection Circuitry
- Wired Remote Bass Control Included
- Double Sided PCB

Active Lp Crossover

Large Input Connectors



Subsonic Filter



Bass Remote Included

MODEL #	DESCRIPTION	2 Ω @ 14.4 V	4 Ω @ 14.4 V	CAPABILITY	M CARTON
HYP1200D	Class AB Monoblock Amplifier	1 x 1200 Watts	1 x 600 Watts	2 Ω Mono	4
MODEL #	DESCRIPTION	1 Ω @ 14.4 V	2 Ω @ 14.4 V	CAPABILITY	M CARTON
HYP1600D	Class D Monoblock Amplifier	1 x 1600 Watts	1 x 800 Watts	1 Ω Mono	4
HYP2200D	Class D Monoblock Amplifier	1 x 2200 Watts	1 x 1100 Watts	1 Ω Mono	4
HYP2800D	Class D Monoblock Amplifier	1 x 2800 Watts	1 x 1400 Watts	1 Ω Mono	4
HYP3600D	Class D Monoblock Amplifier	1 x 3600 Watts	1 x 1800 Watts	1 Ω Mono	4
HYP4800D	Class D Monoblock Amplifier	1 x 4800 Watts	1 x 2400 Watts	1 Ω Mono	3

### SPECIFICATIONS:

- Signal to Noise Ratio: >90dB
- Low Pass Crossover: 50Hz - 220Hz
- Subsonic Filter: 0-50Hz
- Bass Boost @ 45Hz: 0-6dB-12db
- Frequency Response: 10Hz - 250Hz
- THD @ 1%: <0.1%
- Input Sensitivity: 200mV - 6V

### Dimensions

	L	H	W
HYP1200D	9.05" / 230mm	2.20" / 56mm	6.10" / 155mm
HYP1600D	10.11" / 257mm	2.20" / 56mm	6.10" / 155mm
HYP2200D	10.82" / 275mm	2.20" / 56mm	6.10" / 155mm
HYP2800D	10.11" / 257mm	2.20" / 56mm	6.10" / 155mm
HYP3600D	13.30" / 338mm	2.20" / 56mm	6.10" / 155mm
HYP4800D	19.75" / 502mm	2.20" / 56mm	6.10" / 155mm



## ■ HYP2BE Digital Bass Enhancer With Dual Function Dash Control



PARAMETRIC  
BASS EQ



BALANCED  
RCA INPUTS

### FEATURES:

- 2 Channel Digital Bass Restoration
- Parametric Bass Equalization
- Variable Center Frequency Control
- Selectable Balanced/ Non-balanced RCA inputs
- Selectable Ground Isolation Switch
- Selectable Bass Output Control
- PWM Power Supply
- Dash Mount Remote Control W/ Selectable Subsonic Filter

Master Carton: 20 PCS

### DIMENSIONS:

L: 7.20" / 182.88mm  
W: 5.20" / 132.08mm  
H: 1.50" / 38.1mm





## ■ HWP12 12" 4 Ω DVC SUBWOOFER

### FEATURES:

- High Temperature Voice Coil
- Non-Pressed Paper cone
- Double Stitched Foam Surround
- High Roll Foam Surround
- Heavy Gauge Die-Cast Aluminum Basket
- Wrap Around Mounting Gasket
- Heavy Gauge Spring Terminals
- Protective magnet cover

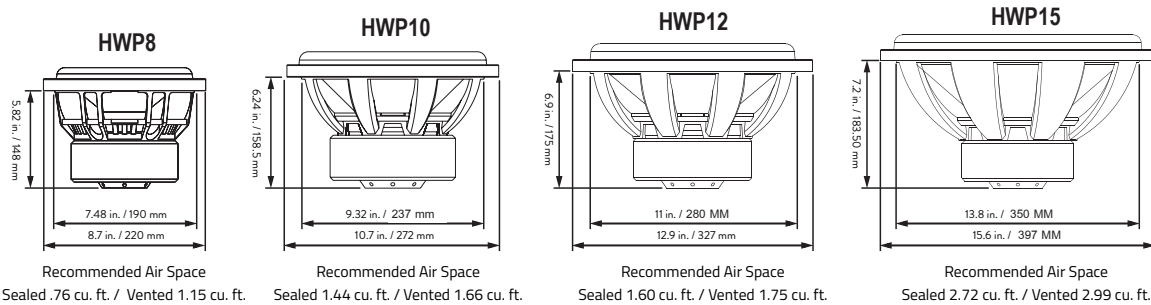

MODEL #	SUBWOOFER STRUCTURE	MAX POWER	NOMINAL POWER	IMPEDENCE	M CARTON
HWP8	8" / 20.3cm DVC Subwoofer	1000 Watts	500 Watts	Dual 4Ω Voice Coil	2
HWP10	10" / 25.4cm DVC Subwoofer	2000 Watts	1000 Watts	Dual 4Ω Voice Coil	2
HWP12	12" / 30.4cm DVC Subwoofer	2000 Watts	1000 Watts	Dual 4Ω Voice Coil	2
HWP15	15" / 38.1cm DVC Subwoofer	2000 Watts	1000 Watts	Dual 4Ω Voice Coil	1

## SUBWOOFER AMPLIFIER COMPATIBILITY CHART

SUBWOOFER	NUMBER OF SUBWOOFERS	RECOMMENDED AMPLIFIER OPTION 1	RECOMMENDED AMPLIFIER OPTION 2
HWP8	1 SUB @ 2 Ω	HX1200.1D	HYP1600D
HWP8	2 SUBS @ 1 Ω	HX2400.1D	HYP2200D
HWP10	1 SUB @ 2 Ω	HX2400.1D	HYP2200D
HWP10	2 SUBS @ 1 Ω	HX2400.1D	HYP1600D
HWP12	2 SUBS @ 1 Ω	HX3600.1D	HYP200D
HWP15	2 SUBS @ 1 Ω	HX3100.1D	HYP2800D

■ **HW12D4**  
12" 4 Ω DVC SUBWOOFER

**1500**  
**WATTS**



IMPP Cone



High Temperature  
Voice Coil

Works in Sealed or  
Vented Enclosures

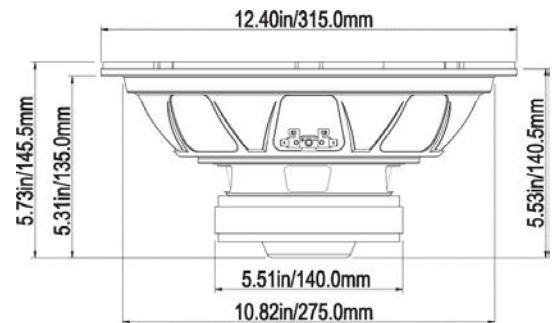

Recommended Air Space  
Sealed 1.15 cu. ft. / Vented 1.42 cu. ft.

**FEATURES:**

- 2.0" / 5.8mm KSV Voice Coil
- PP Cone W/ Foam Surround
- Injection Molded PP Dust Cap
- High Energy Strontium Ferrite Magnet
- Convection Vented Monolithic Forged Yoke
- Electro-Plated Finished Top and Bumped Bottom Plate
- CAD Optimized Electro Mechanical and Magnetic Design
- Low Stress Connecting Leads
- Poly-Cotton Spider
- Fast On Speaker Terminals

MODEL #	STRUCTURE	MAX POWER	NOMINAL POWER	IMPEDANCE	M. CARTON
HW12D4	12" / 30.48cm DVC Subwoofer	1500 W	300 W	4Ω	2



# Subwoofers

# 900 WATTS



## FEATURES:

- 1.5" / 3.81cm KSV Voice Coil
- PP Cone W/ Foam Surround
- Injection Molded PP Dust Cap
- High Energy Strontium Ferrite Magnet
- Convection Vented Monolithic Forged Yoke
- Electro-Plated Finished Top and Bumped Bottom Plate
- CAD Optimized Electro Mechanical and Magnetic Design
- Low Stress Connecting Leads
- Poly-Cotton Spider
- Fast On Speaker Terminals

Efficient Power Design

## HEW12 12" 4 Ω SVC SUBWOOFER

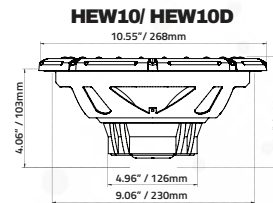

Recommended Air Space  
Sealed 1.0 cu. ft. / Vented 1.37 cu. ft.

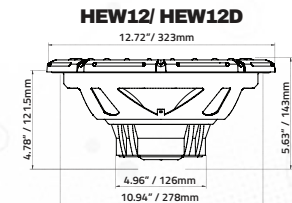

Recommended Air Space  
Sealed 1.25 cu. ft. / Vented 1.68 cu. ft.

MODEL #	SUBWOOFER STRUCTURE	MAX POWER	NOMINAL POWER	IMPEDENCE	M CARTON
HEW10	10" / 25.4cm SVC Subwoofer	900 Watts	150 Watts	Single 4Ω Voice Coil	4
HEW12	12" / 30.48cm SVC Subwoofer	900 Watts	150 Watts	Single 4Ω Voice Coil	4
HEW12D	12" / 30.48cm DVC Subwoofer	900 Watts	150 Watts	Dual 4Ω Voice Coil	4

■ **HPR065K**  
6.5" PRO AUDIO COMPONENT KIT

**350**  
**WATTS**

**FEATURES:**

- Ultra High Efficiency Pro Audio 6.5"/16.51cm Component
- Shallow Mount Application
- Multi Application Use
- Paper Cone with Cloth Edge Accordion Surround
- Custom Embossed Protective Grills Included
- 1.5" / 3.81cm High Temperature Voice Coil
- Stamped Steel Basket



High Efficiency Design

Passive Crossover

Weather Treated Paper Cone

HM65PRO4 - MIDRANGE

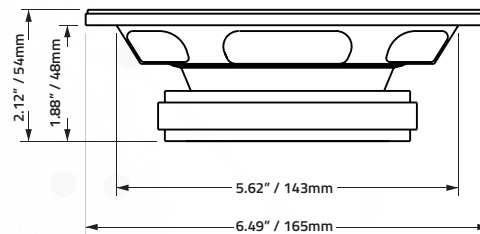

HT3PRO - TWEETER

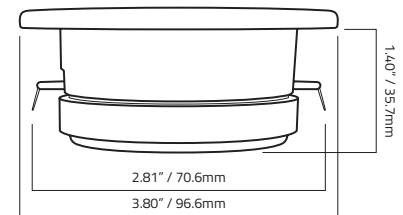

MODEL #	STRUCTURE	MAX POWER	NOMINAL POWER	IMPEDANCE	FREQUENCY RESPONSE	M. CARTON
HPR065K	6.5" / 16.51cm Component	350 Watts	175 Watts	4Ω	88hz - 18khz Hz	4



# Pro Audio Speakers & Tweeters

## ■ HM65PRO4 6.5" PRO AUDIO SPEAKER

Shallow Mounting

## ■ HM8PRO4 8" PRO AUDIO SPEAKER

Weather Treated Paper Cone



### FEATURES:

- Ultra High Efficiency Pro Audio Speaker
- Shallow Mount Application
- Multi Application Use
- Paper Cone with Cloth Edge Accordion Surround
- Custom Embossed Protective Grills Included
- 1.5" / 3.81cm High Temperature Voice Coil
- Stamped Steel Basket

**SOLD IN  
PAIRS**

MODEL #	STRUCTURE	MAX POWER	NOMINAL POWER	IMPEDANCE	FREQUENCY RESPONSE	M. CARTON
HM65PRO4	6.5" / 16.51cm Pro Midrange	250 Watts	150 Watts	4Ω	45Hz - 25KHZ	6
HM8PRO4	8" / 20.3cm Pro Midrange	300 Watts	175 Watts	4Ω	45Hz - 25KHZ	4

## ■ HT3PRO 3" PRO TWEETER

Die-Cast  
Aluminum Chassis

**300  
WATTS**

### FEATURES:

- Aluminum Diaphragm
- 1" / 2.54cm Voice Coil Diameter
- 5.4 oz Magnet
- Shallow Mount Application
- 101 dB Sensitivity
- Direct Connect Speaker Terminals
- Die-cast Aluminum Construction
- 1 Pair



High Output  
Aluminum Dome

**SOLD IN  
PAIRS**

MODEL #	STRUCTURE	MAX POWER	NOMINAL POWER	IMPEDANCE	FREQUENCY RESPONSE	M. CARTON
HT3PRO	3" / 7.62cm Pro Tweeter	300 Watts	150 Watts	4Ω	2k - 20k Hz	12



■ **HS3 1T**  
1" Aluminum Dome Tweeter



■ **HS3 35**  
3.5" 2-Way Speakers



■ **HS3 46**  
4X6" 2-Way Speakers



■ **HS3 40**  
4" 2-Way Speakers  
*Includes Grill*



■ **HS3 50**  
5.25" 2-Way Speakers  
*Includes Grill*



■ **HS3 60** 6.5" 2-Way Speakers  
*Includes Grill*

MODEL #	STRUCTURE	MAX POWER	NOMINAL POWER	IMPEDANCE	FREQUENCY RESPONSE	M. CARTON
HS3 1T	1" Aluminum Dome Tweeters	150 Watts	50 Watts	4Ω	-	24
HS3 35	3.5" 2 - Way Speakers	75 Watts	35 Watts	4Ω	75Hz - 35KHZ	12
HS3 40	4" 2 - Way Speakers	80 Watts	40 Watts	4Ω	75Hz - 20 KHz	10
HS3 46	4 x 6" 2-Way Speakers	80 Watts	40 Watts	4Ω	65Hz - 20KHZ	12
HS3 50	5.25" 2- Way Speakers	90 Watts	45 Watts	4Ω	55Hz - 20 KHz	10
HS3 60	6.5" 2- Way Speakers	150 Watts	50 Watts	4Ω	35Hz - 20 KHz	8



# HS3 Speaker Series

## ■ HS3 SERIES

### FEATURES:

- 2 Way Speaker
- PEI Dome Tweeter
- Polypropylene Cone
- Rubber Surround
- High Temperature Voice Coil
- Rigid Stamp Steel Basket

## ■ HS3 65C

6.5" Component Speakers



*Includes Grill*



**Aluminum Dome Tweeter**



## ■ HS3 57

5x7" 2-Way Speakers

## ■ HS3 69

6 x 9" 3- Way Speakers

*Includes Grill*



MODEL #	STRUCTURE	MAX POWER	NOMINAL POWER	IMPEDANCE	FREQUENCY RESPONSE	M. CARTON
<b>HS3 57</b>	5 x 7" 2 - Way Speakers	125 Watts	55 Watts	4Ω	40 Hz - 20kHz	10
<b>HS3 65C</b>	6.5" Component Speakers	175 Watts	75 Watts	4Ω	40 Hz - 20kHz	6
<b>HS3 69</b>	6 x 9" 3 - Way Speakers	150 Watts	75 Watts	4Ω	40 Hz - 20kHz	4



■ **HYS35**  
3.5" Coaxial



■ **HYS40**  
4" Coaxial

■ **HYS46**  
4x6" Coaxial



■ **HYS50**  
5.25" Coaxial



■ **HYS57**  
5x7" Coaxial

MODEL #	STRUCTURE	MAX POWER	NOMINAL POWER	IMPEDANCE	FREQUENCY RESPONSE	M. CARTON
<b>HYS35</b>	3.5" / 8.89cm Coaxial	200 Watts	35 Watts	4Ω	75Hz - 25KHZ	12
<b>HYS40</b>	4" / 10.16cm Coaxial	250 Watts	40 Watts	4Ω	50Hz - 25 KHz	12
<b>HYS46</b>	4x6" / 10.16cm x 15.24cm Coaxial	250 Watts	40 Watts	4Ω	75Hz - 25KHZ	12
<b>HYS50</b>	5.25" / 13.33cm Coaxial	500 Watts	50 Watts	4Ω	50Hz - 25 KHz	12
<b>HYS57</b>	5X7" / 12.7cm x 17.78cm Coaxial	350 Watts	60 Watts	4Ω	45Hz - 25 KHz	10



# HYS Speaker Series

- **HYS69G**  
6X9" 4-Way  
Includes Grill



- **HYS60**  
6.5" 2 Way Speaker  
*\*Does Not Include Grill*

## ■ HYS SERIES

### FEATURES:

- Coaxial Speaker
- Mylar Dome Tweeter
- Polypropylene Cone
- Rubber Surround
- Rigid Stamp Steel Basket

- **HYS60G**  
6.5" 2 Way Speaker



*Includes Grill*

MODEL #	STRUCTURE	MAX POWER	NOMINAL POWER	IMPEDANCE	FREQUENCY RESPONSE	M. CARTON
<b>HYS69G</b>	6x9" / 137.16cm 4-Way Speaker	400 Watts	75 Watts	4Ω	35 Hz - 28kHz	4
<b>HYS60</b>	6.5" / 16.51 cm 2 Way Speaker	350 Watts	60 Watts	4Ω	45 Hz - 25kHz	8
<b>HYS60G</b>	6.5" / 16.51 cm 2 Way Speaker	350 Watts	60 Watts	4Ω	45 Hz - 25kHz	8

### ■ HS1 65C 6.5" COMPONENT KIT



#### FEATURES:

- 150 Watts Dynamic Power
- 65 Watts Nominal Power
- PEI Tweeter
- Polypropylene Cone
- Foam Surround
- 1" High Temperature Voice Coil
- Rigid Stamp Steel Basket
- Mesh Grill Included
- Frequency Response: 65Hz-20KHz
- Impedance: 4Ω

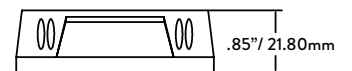
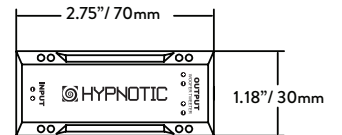
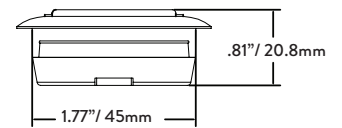
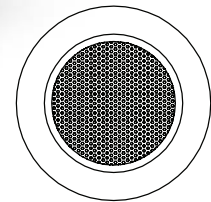
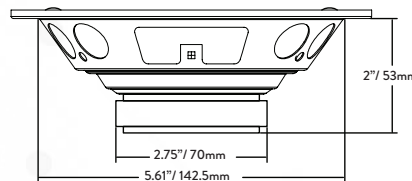
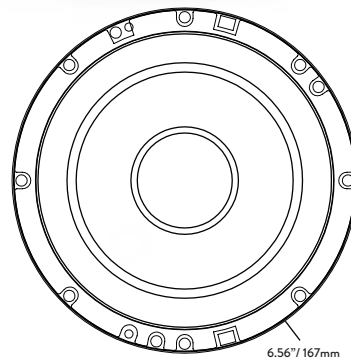

**GRILLS INCLUDED**



**4Ω**



**1" HIGH TEMP VOICE COIL**





## ■ HCKOANL

0 GA 100% COPPER  
ANL AMP KIT

100% COPPER

### KIT CONTENTS:

- 15' (4.6M) Gray / White 100% Copper Soft Touch RCA Cable
- 15' (4.6 M) 0 Ga. Red 100% Copper Soft Touch Power Cable
  - 15' (4.6M) 18 Ga. Blue 100% Copper Remote Wire
  - 17' (5.2M) 16 Ga. White / Gray Speaker Cable
- 2' (0.6M) 0 Ga. Gray 100% Copper Soft Touch Ground Cable
  - ANL Heat Resistant Fuse Holder
  - 150 Amp ANL Fuse
- Accessories : Wire Ties, Ring Terminals, Butt Connectors, Spades, Grommet & Split loom

**MASTER CARTON: 6**





**100% COPPER**

■ **HCK4ANL**  
**4 GA 100% COPPER**  
**ANL AMP KIT**

**KIT CONTENTS:**

- 15' (4.6M) Gray / White 100% Copper Soft Touch RCA Cable
- 15' (4.6 M) 4 Ga. Red 100% Copper Soft Touch Power Cable
  - 15' (4.6M) 18 Ga. Blue 100% Copper Remote Wire
  - 17' (5.2M) 16 Ga. White / Gray Speaker Cable
- 2' (0.6M) 4 Ga. Gray 100% Copper Soft Touch Ground Cable
  - ANL Heat Resistant Fuse Holder
  - 60 Amp ANL Fuse
- Accessories : Wire Ties, Ring Terminals, Butt Connectors, Spades, Grommet & Split loom

**MASTER CARTON: 8**



**100% COPPER**

■ **HCK8MANL**  
**8 GA 100% COPPER**  
**MINI ANL AMP KIT**

**KIT CONTENTS:**

- 15' (4.6M) Gray / White 100% Copper Soft Touch RCA Cable
- 15' (4.6M) 8 Ga. Red 100% Copper Soft Touch Power Cable
- 15' (4.6M) 18 Ga. Blue 100% Copper Remote Wire
- 17' (5.2M) 16 Ga. White / Gray Speaker Cable
- 2' (0.6M) 8 Ga. Gray 100% Copper Soft Touch Ground Cable
- Mini ANL Heat Resistant Fuse Holder
- 30 Amp Mini ANL fuse
- Accessories : Wire Ties, Ring Terminals, Butt Connectors, Spades, Grommet & Split loom

**MASTER CARTON: 12**





## ■ HKOANL 0 GAUGE ANL AMP KIT

### KIT CONTENTS:

- 15' (4.6M) Gray/White Soft Touch RCA Cable
- 15' (4.6M) 0 Ga. Blue Soft Touch Power Cable
- 15' (4.6M) 18 Ga. Blue Remote Wire
- 17' (5.2M) 16 Ga. White/Dark Gray Speaker Cable
- 2' (0.6M) 0 Ga. Dark Gray Soft Touch Ground Cable
- ANL Heat Resistant Fuse Holder
- 150 Amp ANL fuse
- Accessories : Wire Ties, Ring Terminals, Butt Connectors, Spades, Split loom & Grommet

### MASTER CARTON: 6



## ■ HK4ANL 4 GAUGE ANL AMP KIT

### KIT CONTENTS:

- 15' (4.6M) Gray/White Soft Touch RCA Cable
- 15' (4.6M) 4 Ga. Blue Soft Touch Power Cable
- 15' (4.6M) 18 Ga. Blue Remote Wire
- 17' (5.2M) 16 Ga. White/Dark Gray Speaker Cable
- 2' (0.6M) 4 Ga. Dark Gray Soft Touch Ground Cable
- ANL Heat Resistant Fuse Holder
- 60 Amp ANL fuse
- Accessories : Wire Ties, Ring Terminals, Butt Connectors, Spades, Split loom & Grommet.

### MASTER CARTON: 8



## ■ HK4AGU 4 GAUGE AGU AMP KIT

### KIT CONTENTS:

- 15' (4.6M) Gray/White Soft Touch RCA Cable
- 15' (4.6M) 4 Ga. Blue Soft Touch Power Cable
  - 15' (4.6M) 18 Ga. Blue Remote Wire
- 17' (5.2M) 16 Ga. White/Dark Gray Speaker Cable
- 2' (0.6M) 4 Ga. Dark Gray Soft Touch Ground Cable
  - AGU Heat Resistant Fuse Holder
  - 60 Amp AGU Fuse
- Accessories : Wire Ties, Ring Terminals, Butt Connectors, Spades, Split Loom & Grommet.

**MASTER CARTON: 8**



## ■ HK8AGU 8 GAUGE AGU AMP KIT

### KIT CONTENTS:

- 15' (4.6M) Gray/White Soft Touch RCA Cable
- 15' (4.6M) 8 Ga. Blue Soft Touch Power Cable
- 15' (4.6M) 18 Ga. Blue Remote Wire
- 17' (5.2M) 16 Ga. White/Dark Gray Speaker Cable
- 2' (0.6M) 8 Ga. Dark Gray Soft Touch Ground Cable
- AGU Heat Resistant Fuse Holder
- 30 Amp AGU Fuse
- Accessories : Wire Ties, Ring Terminals, Butt Connectors, Spades, Split loom & Grommet.

**MASTER CARTON: 12**





# RCA Cables

## ■ HSXSERIES PREMIUM RCA CABLES



### FEATURES:

- Signal Transfer System with OFC twisted center conductors
- Translucent Red/Black Soft-Touch dual conductor Exterior Jacket
- Proprietary molded Grip design with gold metal pin
- High Strand Count Copper conductor
- Excellent Audio accuracy and performance

MODEL #	LENGTH	M CARTON
HSX1.5	1.5' (0.45m)	200
HSX3	3' (0.9m)	200
HSX6	6' (1.82m)	100
HSX9	9' (2.74m)	50
HSX12	12' (3.65m)	50
HSX15	15' (4.5m)	50
HSX17	17' (5.1m)	50
HSX20	20' (6m)	50
HSXY2M	Y ADAPTER 2M / 1F	200
HSXY2F	Y ADAPTER 2F / 1M	200

## ■ HXL SERIES HIGH PERFORMANCE RCA CABLES

MODEL #	LENGTH	M CARTON
HXL1.5	1.5' (0.45m)	250
HXL3	3' (0.9m)	200
HXL6	6' (1.82m)	200
HXL 9	9' (2.74m)	200
HXL12	12' (3.65m)	100
HXL15	15' (4.5m)	100
HXL17	17' (5.1m)	80
HXL20	20' (6m)	50
HXLY2M	Y ADAPTER 2M / 1F	500
HXLY2F	Y ADAPTER 2F / 1M	500

### FEATURES:

- High Performance Jacket RCA
- Shielded with Gold Plated Tips
- Enhanced Signal Quality





### HPWSERIES PREMIUM POWER WIRE



MODEL #	COLOR	GAUGE	LENGTH	M. CARTON
HPW0R50	RED	0	ROLL 50' / 15.24m	2
HPW4R100	RED	4	ROLL 100' / 30.48m	2
HPW8R250	RED	8	ROLL 250' / 76.2m	2

### ■ HSWSERIES PREMIUM SPEAKER WIRE

2 COLOR COMBINATION

RED / BLACK



MODEL #	COLOR	GAUGE	LENGTH	M. CARTON
HSW10G100	RED/BLACK	10	ROLL 100' / 30.48m	8
HSW12G250	RED/BLACK	12	ROLL 250' / 76.2m	4
HSW16G500	RED/BLACK	16	ROLL 500' / 152.4m	2
HSW18G1000	RED/BLACK	18	ROLL 1000' / 304.8m	2



# Capacitors & Converters

## ■ HHL5R

HI-LOW LEVEL CONVERTER  
WITH REMOTE TRIGGER OUTPUT



### FEATURES:

- 2 Channel RCA Stereo Input Capacity
- 30 Watt High level Input Capacity
- Individual Input Gain Controls Remote Trigger Output

**MASTER CARTON: 100**

## ■ HCAP2KF

HIGH PERFORMANCE  
CAPACITOR



### FEATURES:

- 2000 Watts
- 2 Farad Capacitance (-10% + 50%)
- 20 Volts Max Operating Volts
- 85° Degrees C-Max Operating Temperature
- Blue Digital Voltage Display with 2 LED'S
- Includes Mounting Bracket and Charging Bulb

**MASTER CARTON: 12**



# HYPNOTIC™

Audio for Mind, Body & Soul

[www.hypnoticusa.com](http://www.hypnoticusa.com)



302 Hanmore Industrial Parkway, Harlingen, TX 78550  
Toll Free: (877) 787- 0101 / Fax: (956) 421- 4513  
Contact us at: [sales@dbdrive.net](mailto:sales@dbdrive.net)  
Tech Support: [support@dbdrive.net](mailto:support@dbdrive.net)  
Printed in China / HYPCAT24A

