



# DB DRIVE™

---

## *COMPETITION GRADE*

---

### SUBWOOFERS

<b>G7</b> 18.1		<b>G7</b> 15.2
<b>G7</b> 15.1		<b>G7</b> 12.2
<b>G7</b> 12.1		<b>G7</b> 10.2
<b>G7</b> 10.1		<b>G7</b> 8.4
<b>G7</b> 8.2		

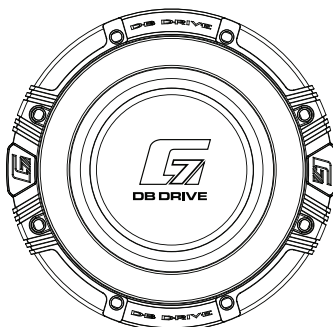

## **User's Manual**

• Installation Instructions / Owner's Manual •

Due to continuous improvement of the product, the specifications are subject to change without notice.

## Introduction

Congratulations on your purchase of a DB Drive state-of-the-art subwoofer. Your selection of a DB Drive car audio product indicates a true appreciation of fine musical reproduction. Whether adding to an existing system or including your DB Drive subwoofer in a new system, you are certain to notice immediate performance benefits.

### Product Commitment

DB's engineering professionals harnessed years of expertise, experience and passion, coupled with exhaustive testing and creative design to develop the optimal product and performance for your musical enjoyment. This is our commitment to you. It's what you deserve and have come to expect from DB DRIVE. We appreciate the confidence and look forward to your positive experience.

### Keep Your Sales Receipt

Take this time to attach your sales receipt to the manual and put it in a safe place. In case of any unforeseen reason this product may need warranty service, your receipt will be necessary to establish purchase date.

### Recommendation

A power subwoofer's performance is only as good as its installation. Proper installation will maximize the system's overall performance. It is recommended that you have our product installed by an authorized DB Drive retailer. However, if you decide to install it yourself, please carefully read through this manual and take your time to do a quality installation.

### Optimal Product Choice

To get the maximum performance out of your stereo system, we recommend using 100% authentic DB Drive electronics and DB LINK wiring and accessories. Matching DB Drive amplifiers and speakers with your state-of-the-art electronics purchase is critical to optimize your system's performance. Wiring is the lifeblood of a system, make sure your audio system has the adequate current and signal transfer it deserves and needs. DB Link has it all, from wiring rolls; speaker, power, ground and remote to amplifier kits, RCA's, and fuse holders, distribution blocks and battery connectors. Insist on getting the best, DB LINK. It's what you deserve to get the optimum performance from your audio system.

## IMPORTANT!

Before making any connections, disconnect the car's battery until the installation is completed to avoid possible damage to the electrical system.

## WARNING!

Exposure to a high power sound system can cause hearing loss or damage. Listening to your system at loud levels while driving will impair your ability to hear traffic sounds and emergency vehicles. Use common sense when listening to your system.

Serial # \_\_\_\_\_ Model # \_\_\_\_\_

# PRODUCT FEATURES

- Xtreme Excursion Surround
- True Carbon Fiber Dust Cap
- Proprietary Reinforced Aluminum Die-Cast Basket
- Tri-Layer Progressive Dampeners with Integrated Tinsel Leads
- Radial Balanced Paper Glass Fibrillated Mixed Cone
- 8 Gauge Push Spring Input Terminals
- 4-Layer Aluminum Flat Wire Voice Coil
- Triple Stacked Ferrite Magnets
- Excursion Induced Motor Cooling
- Aluminum Anodized Former With Reinforced Triple Joint

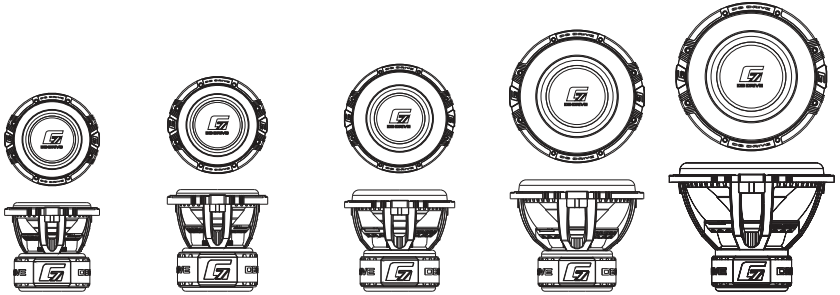

	G7 8.2 / G7 8.4	G7 10.1 / G7 10.2	G7 12.1 / G7 12.2	G7 15.1 / G7 15.2	G7 18.1
Structure	8" (20.3cm)	10" (25.4cm)	12" (30.48cm)	15" (38.1cm)	18" (45.72cm)
Max Power	2500 Watts	8000 Watts	8000 Watts	8000 Watts	8000 Watts
Nominal Power	1250 Watts	4000 Watts	4000 Watts	4000 Watts	4000 Watts
Impedance	2.7" (6.85cm) 2Ω Dual Voice Coil/ 4Ω Dual Voice Coil	3" (7.62cm) 1Ω Dual Voice Coil/ 2Ω Dual Voice Coil	3" (7.62cm) 1Ω Dual Voice Coil/ 2Ω Dual Voice Coil	3" (7.62cm) 1Ω Dual Voice Coil/ 2Ω Dual Voice Coil	3" (7.62cm) 1Ω Dual Voice Coil

# PRODUCT SPECIFICATIONS

TS	G7 8.2	G7 8.4	G7 10.1	G7 10.2	G7 12.1	G7 12.2	G7 15.1	G7 15.2	G7 18.1
FS	48.936Hz	50.135Hz	34.043Hz	35.925Hz	29.414Hz	30.346Hz	24.512Hz	23.461Hz	27.002 Hz
Re	2x2Ω	2x4Ω	2x1Ω	2x2Ω	2x1Ω	2.2Ω	2x1Ω	2x2Ω	2x1Ω
Qms	2.010	2.158	2.314	2.542	2.108	2.269	2.182	2.466	2.336
Qes	0.699	0.776	0.623	0.717	0.443	0.613	0.473	0.573	0.828
Qts	0.518	0.571	0.491	0.559	0.366	0.482	0.389	0.465	0.611
VAS	3.478 L	3.829 L	15.567 L	13.164 L	21.008 L	22.479 L	48.507L	79.836L	106.732 L
Cms	49.843 mm/N	52.344 mm/N	73.165 mm/N	61.872 mm/N	66.565 mm/N	71.225 mm/N	59.964 mm/N	98.692 mm/N	58.438 mm/N
BL	18.336 N/A	21.660 N/A	11.983 N/A	17.881 N/A	16.026 N/A	19.610 N/A	17.899 N/A	19.601 N/A	13.060 N/A
Mms	212.219 g	192.525 g	298.726 g	317.218 g	439.839 g	386.199 g	703.084 gr	466.313 g	594.496 g
SPL	79.5dB	79.8dB	81.8dB	81.2dB	82.7dB	82dB	83.7dB	84.4dB	85.9 dB
Xmax	20mm	20mm	35mm	35mm	35mm	35mm	35mm	35mm	35mm

# PRODUCT DIMENSIONS

- A** Frame Diameter
- B** Mounting Depth
- C** Cutout Diameter

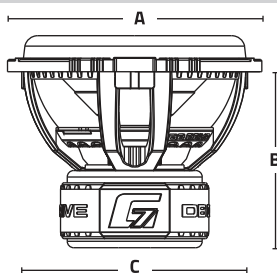

	G7 8.2 / G7 8.4	G7 10.1 / G7 10.2	G7 12.1 / G7 12.2	G7 15.1 / G7 15.2	G7 18.1
<b>A</b> Frame Diameter	9.17 in. (233 mm)	12 in. (304.8 mm)	12.91 in. (328 mm)	15.82 in. (402 mm)	18.78 in. (477 mm)
<b>B</b> Mounting Depth	7.14 in. (181.5 mm)	9 in. (228.6 mm)	9.6 in. (244 mm)	10.78 in. (274 mm)	12.4 in. (315 mm)
<b>C</b> Cutout Diameter	7.48 in. (190 mm)	10.25 in. (260.35 mm)	11.14 in. (283 mm)	13.85 in. (352 mm)	16.67 in. (423.5 mm)

## RECOMMENDED ENCLOSURES

The purpose of the information below is to help you select the most appropriate type of enclosure for your application. We have selected the two most popular enclosure types and their performance benefits.

**Sealed Enclosure** (Air-Suspension design): Characteristically simpler to make, sealed enclosures usually are better at controlling the woofer's excursion and performance at lower frequencies. The added control allows for higher power handling or use of a bigger amplifier. The secret is to maintain a perfect seal. Using glues and sealants at all seams is recommended to prevent leaks and integrity of the enclosure. The size or volume of the enclosure will directly affect the performance of the woofer. Smaller enclosures generally provide the desired bump to the frequency response curb and greater SPL. Larger enclosures will provide a lower but flatter response for deeper bass. In general, the benefit to the sealed enclosure versus a ported enclosure is a smaller foot print, simpler build with higher power handling, a more linear flat response, superior sound quality and extended low frequency output.

**Ported Enclosure** (Bass-Reflex or Vented): A ported enclosure is simply a sealed enclosure with a port or vent added to the sealed design for the purpose of tuning the enclosure to higher output at the desired tuned frequency, typically 3db or higher. Another advantage of a ported enclosure is the reduction of cone motion for the speaker, thus distortion at higher power levels within the tuned frequency response of the port. A drawback is that building a ported enclosure is more complex than sealed. Having the wrong port or vent could result in poor sound, and the potential of damaging a woofer when played too loud or out of the tuning frequency. Thus we recommend not guessing, please follow the guidelines listed in this manual or go to a professional. In general, the benefit of a ported enclosure versus a sealed is higher volume output at the tuned frequency, stronger bass output with lower power input.

**Construction:** We recommend using  $\frac{3}{4}$ " MDF (Medium Density Fiberboard) for the construction of an enclosure. It is critical for the side walls of the enclosure not to flex due to the pressure generated by the woofer, bracing might be required. The enclosure sides should be secured together with nails/screwed. We also recommend the use of glues and sealants to maintain the integrity of the enclosure and eliminate leaks.

# RECOMMENDED ENCLOSURES

## Vented

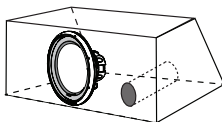

ENCLOSURES	G7 8.2 / G7 8.4	G7 10.1 / G7 10.2	G7 12.1 / G7 12.2	G7 15.1 / G7 15.2	G7 18.1
Woofer Cut-out:	7.48 in. (191 mm)	10.25 in. (260.35 mm)	11.14 in. (283 mm)	13.85 in. (352 mm)	16.67 in. (423.5 mm)
Mounting Depth:	7.14 in. (181.50 mm)	9 in. (228.6 mm)	9.6 in. (244 mm)	10.78 in. (298 mm)	12.4 in. (315 mm)
Sealed Box:	NOT RECOMMENDED	NOT RECOMMENDED	NOT RECOMMENDED	NOT RECOMMENDED	NOT RECOMMENDED
Vented Box:	1.4 cu.ft. (39.64 L)	2.2 cu.ft. (62.29 L)	3.5 cu ft. (99.12 L)	4.5 cu.ft. (127.43L)	6.25 cu.ft. (176.98L)
• Vent Area:	12.57 sq in. (81.09 cm <sup>2</sup> )	24 sq in. (154.83 cm <sup>2</sup> )	52 sq in. (335.4 cm <sup>2</sup> )	75 sq in. (483.87 cm <sup>2</sup> )	80 sq in. (516.12 cm <sup>2</sup> )
• Vent Length:	15 in. (38.1 cm)	28 in. (71.12 cm)	28 in. (71.12 cm)	25 in. (63.5 cm)	30 in. (76.2 cm)
• Tuning:	36Hz	34Hz	34Hz	33Hz	30Hz
Dynamic Power :	2500 Watts	8000 Watts	8000 Watts	8000 Watts	8000 Watts
Nominal Power :	1250 Watts	4000 Watts	4000 Watts	4000 Watts	4000 Watts

# CALCULATING ENCLOSURES

It is recommended to build your enclosure from at least 3/ 4" thick MDF (medium density fiber board). Make sure the enclosure is sealed airtight.

### Calculating External Volume

To calculate box volume, measure the outside Width x Height x Depth of the enclosure. *Example 12" x 14" x 9" = 1512 ÷ 1528" Cubic feet*

Next you must convert cubic inches into cubic feet. To do this, you must divide the cubic inches total by 1728". *Example 1512 ÷ 1728 = .875 Cubic feet*

### Calculating Internal Volume

To calculate the internal (net) volume of the above box you must first multiply the thickness of the wood you are using by Two(2). *Example 3/4" x 2 = 1.5"*

Next subtract 1.5 from each of the outside measurements of the box.

<i>Width</i>	<i>Height</i>	<i>Depth</i>
12 - 1.5 = 10.5	14 - 1.5 = 12.5	9 - 1.5 = 7.5

Multiply the new totals (H x W x D) *Example: 10.5 x 12.5 x 7.5 = 984.375*

Next you must convert cubic inches into cubic feet. To do this, you must divide the cubic inch total by 1728". *Example 984.375 ÷ 1728 = .5696 cubic feet.*

# DVC WIRING CONFIGURATIONS

You can change the wiring configuration of your speakers (Series, Parallel and Series / Parallel) to match the impedance loads that maximizes the power output of you amplifier. Wiring the same woofer or multiple woofers in these three different wiring configurations will result in different impedance loads.

**Series:** Is the method of wiring of alternate positive with negative terminals (string method) (Illustration below)

**Parallel:** Is the method of wiring where you wire match 2 speaker terminals with positive to positive terminal and negative to negative. (Illustration below)

**Series/Parallel:** This configuration is a combination of both series and parallel. We recommend series for the terminal and parallel for the leads to amp. (Illustration below),

**1 x 2Ω DVC SUBWOOFER**  
2Ω

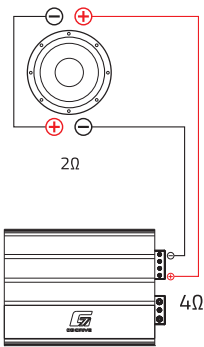

▪ SERIES ▪

**1 x 2Ω DVC SUBWOOFER**  
2Ω

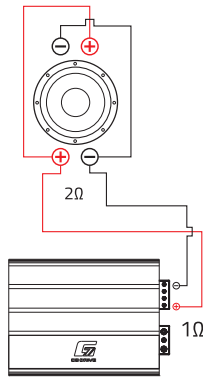

▪ PARALLEL ▪

**2 x 4Ω DVC SUBWOOFERS**

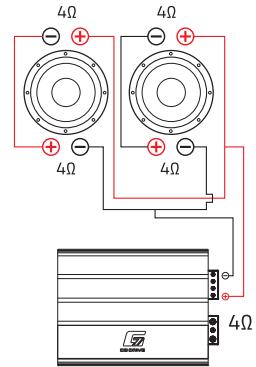

▪ SERIES/PARALLEL ▪

# 1Ω & 2Ω DVC WIRING CONFIGURATIONS

**1 x 2Ω DVC SUBWOOFER**



**1 x 2Ω DVC SUBWOOFER**

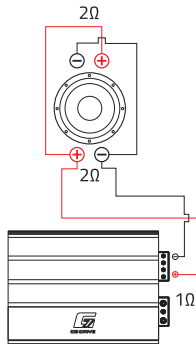

**2 x 1Ω DVC SUBWOOFERS**

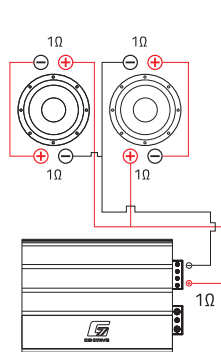

**2 x 2Ω DVC SUBWOOFERS**

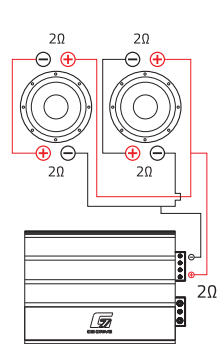

**3 x 2Ω DVC SUBWOOFERS**

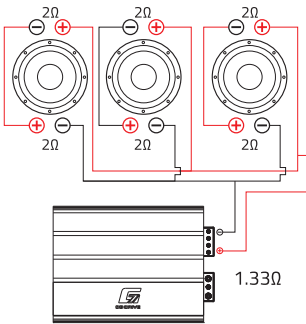

**4 x 2Ω DVC SUBWOOFERS**

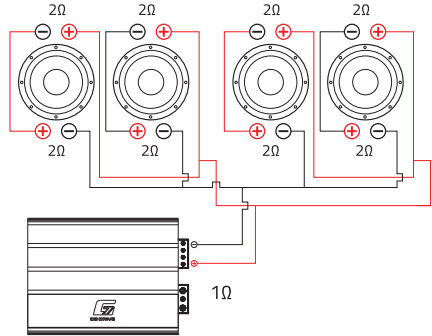

## 4Ω DVC WIRING CONFIGURATIONS

**1 x 4Ω DVC SUBWOOFER**

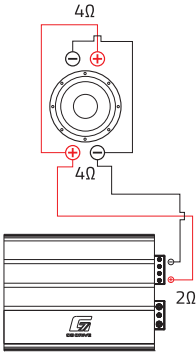

**2 x 4Ω DVC SUBWOOFER**

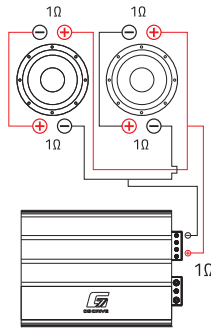

**2 x 4Ω DVC SUBWOOFERS**

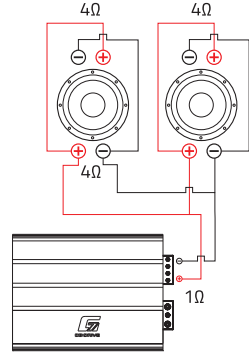

**3 x 4Ω DVC SUBWOOFERS**

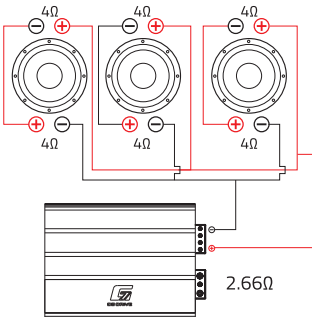

**4 x 4Ω DVC SUBWOOFERS**

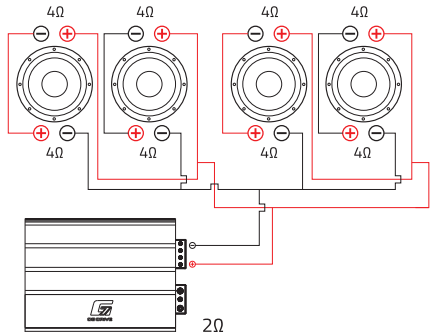

## LIMITED WARRANTY

DB Drive™ G7™ warrants any G7™ Subwoofers purchased in the U.S.A. from an authorized DB Drive™ G7™ dealer. All G7™ Subwoofers are warranted to be free from defects in material and workmanship under normal use and service for a period of one (1) year. This warranty applies to the original purchase only.

DB Drive™ will repair any unit that has been found to be defective and under warranty provided the defect occurs within the one (1) year warranty period.

The warranty does not cover burnt or open voice coils, open tinsel lead wires, ripped surrounds or folded cones that are results of clipped and excessive power and/or improper amplifier calibrations.

This limited warranty does not extend to units that have been subjected to misuse, abuse, neglect, or accident. In DB Drive™'s judgment, products that show evidence of having been altered, modified, or serviced without DB Drive™'s authorization, will be ineligible under this warranty.

The original sales invoice must be presented at the time any warranty will be inspected before any warranty agreement is issued.

Due to the general competition use of the G7™ Subwoofers, warranty is for repairs only. No exchanges or credits will be given.

To obtain warranty service please contact your retailer or visit our website at [www.dbdrive.net](http://www.dbdrive.net) for more details.



DB Research L.L.P. ■ 302 Hanmore Industrial Parkway ■ Harlingen, TX 78550  
Ph: (877) 787-0101 ■ Fax: (956) 421-4513 ■ tech support: [support@dbdrive.net](mailto:support@dbdrive.net)

Designed and Engineered in the U.S.A. 