



HYPNOTIC™

Audio for Mind, Body & Soul



2023 - 2024 PRODUCT GUIDE



FEATURES:

- Class AB Circuitry
- 2 Ohm Load Stereo Capability
- Audiophile Grade Components
- Variable High Pass and Low Pass X-Over
- High Efficiency Mosfet Design
- Heat Management System
- Selectable Bass Boost @ 45Hz
- Thermal Protection Circuitry
- Double Sided PCB

Hypnotic Illuminated Logo

Active Hp/Lp Crossovers



Bridgeable Outputs

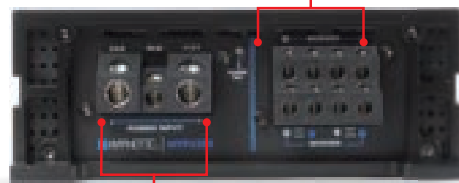

Large Input Connectors

MODEL #	DESCRIPTION	4 Ω @ 14.4 V	2 Ω @ 14.4 V	4 Ω Bridged @ 14.4 V	CAPABILITY	M CARTON
HYP1004	4 Channel Class A/B Amplifier	4 x 100 Watts	4 x 200 Watts	2 x 400 Watts	2 Ω Stereo	4
HYP1254	4 Channel Class A/B Amplifier	4 x 125 Watts	4 x 250 Watts	2 x 500 Watts	2 Ω Stereo	4
HYP1504	4 Channel Class A/B Amplifier	4 x 150 Watts	4 x 300 Watts	2 x 600 Watts	2 Ω Stereo	4
HYP1252	2 Channel Class A/B Amplifier	2 x 125 Watts	2 x 250 Watts	1 x 500 Watts	2 Ω Stereo	5

MODELS:	HYP1004 / HYP1254	HYP1504
• Ch 1-2/ 3-4 High Pass Xover:	40Hz - 3.5KHz	50Hz - 3.5KHz
• Ch 3-4 Low Pass Crossover:	40Hz - 3.5KHz	50Hz - 3.5KHz

MODELS:	HYP1252
• Ch 1-2 High Pass Xover:	50Hz - 3.5KHz
• Ch 1-2 Low Pass Crossover:	50Hz - 3.5KHz

SPECIFICATIONS:

- X-Over Slope: 12 dB
- Bass Boost @ 45Hz: 0 - 6 -12dB
- Input Sensitivity: 285mV - 6V
- Signal to Noise Ratio: >90dB
- THD at Rated Power: <0.5%

Dimensions

	L	H	W
HYP1004	9.84" / 250mm	2.20" / 55.99mm	6.10" / 155mm
HYP1254	10.62" / 270mm	2.20" / 55.99mm	6.10" / 155mm

Dimensions

	L	H	W
HYP1504	13.77" / 350mm	2.20" / 55.99mm	6.10" / 155mm
HYP1252	7.04" / 179mm	2.20" / 55.99mm	6.10" / 155mm

Auto for Mind, Body & Soul



Hypnotic Illuminated Logo

FEATURES:

- Class AB Monoblock Amplifier (HYP1200D)
- Class D Mono Block Amplifier
- 1 Ohm Stable
- 2 Ohm Stable Capability (HYP1200D)
- PWM Mosfet Power Supply
- RCA Line Level Stereo Inputs
- 12dB / Variable Low Pass Crossover
- Variable Subsonic Filter
- Selectable Bass Boost @ 45 Hz
- Thermal Protection Circuitry
- Wired Remote Bass Control Included
- Double Sided PCB

Active Lp Crossover

Large Input Connectors



Subsonic Filter



Bass Remote Included

MODEL #	DESCRIPTION	2 Ω @ 14.4 V	4 Ω @ 14.4 V	CAPABILITY	M CARTON
HYP1200D	Class AB Monoblock Amplifier	1 x 1200 Watts	1 x 600 Watts	2 Ω Mono	4

MODEL #	DESCRIPTION	1 Ω @ 14.4 V	2 Ω @ 14.4 V	CAPABILITY	M CARTON
HYP1600D	Class D Monoblock Amplifier	1 x 1600 Watts	1 x 800 Watts	1 Ω Mono	4
HYP2200D	Class D Monoblock Amplifier	1 x 2200 Watts	1 x 1100 Watts	1 Ω Mono	4
HYP2800D	Class D Monoblock Amplifier	1 x 2800 Watts	1 x 1400 Watts	1 Ω Mono	4
HYP3600D	Class D Monoblock Amplifier	1 x 3600 Watts	1 x 1800 Watts	1 Ω Mono	4
HYP4800D	Class D Monoblock Amplifier	1 x 4800 Watts	1 x 2400 Watts	1 Ω Mono	4

SPECIFICATIONS:

- Signal to Noise Ratio: >90dB
- Low Pass Crossover: 50Hz - 220Hz
- Subsonic Filter: 0-50Hz
- Bass Boost @ 45Hz: 0-6dB-12db
- Frequency Response: 10Hz - 250Hz
- THD @ 1%: <0.1%
- Input Sensitivity: 200mV - 6V

Dimensions

	L	H	W
HYP1200D	9.05" / 230mm	2.20" / 55.99mm	6.10" / 155mm
HYP1600D	10.11" / 257mm	2.20" / 55.99mm	6.10" / 155mm
HYP2200D	10.82" / 275mm	2.20" / 55.99mm	6.10" / 155mm

Dimensions

	L	H	W
HYP2800D	10.11" / 257mm	2.20in / 55mm	6.10in / 155mm
HYP3600D	13.30" / 338mm	2.20in / 55mm	6.10in / 155mm
HYP4800D	19.75" / 502mm	2.20in / 55mm	6.10in / 155mm

Auto for Mind, Body & Soul

■ HYP1BE Digital Bass Enhancer



FEATURES:

- Dash Mountable Remote Control
- PFM Subsonic Filter
- Illuminated Controls
- Illuminated Logo
- Parametric Bass Equalization
- Balanced RCA Inputs
- PWM Power Supply
- Continuously Variable Bass Output Control
- Output Level: up to 13.5 Volt
- Frequency Response: 10Hz - 25KHz
- THD: 0.0015%
- S/N Ratio: <133dB

Master Carton: 10



Subsonic Filter



Auto for Mind, Body & Soul

■ HWP12 12" 4 Ω DVC SUBWOOFER

Die-Cast
Aluminum Basket

Works in Sealed or
Vented Enclosures

Engineered for High SPL



FEATURES:

- High Temperature Voice Coil
- Non-Pressed Paper cone
- Double Stitched Foam Surround
- High Roll Foam Surround
- Heavy Gauge Die-Cast Aluminum Basket
- Wrap Around Mounting Gasket
- Heavy Gauge Spring Terminals
- Protective magnet cover

HWP8

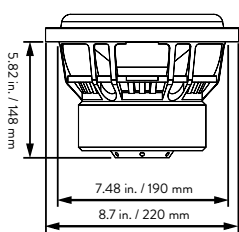

Recommended Air Space

Sealed .76 cu. ft. / Vented 1.15 cu. ft.

HWP10

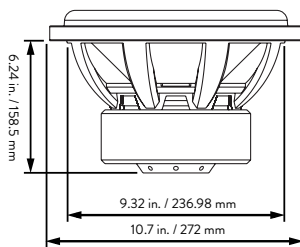

Recommended Air Space

Sealed 1.44 cu. ft. / Vented 1.66 cu. ft.

HWP12

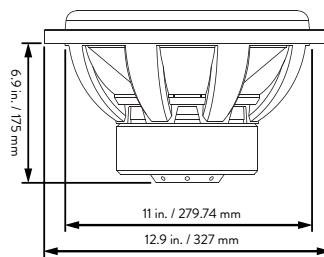

Recommended Air Space

Sealed 1.60 cu. ft. / Vented 1.75 cu. ft.

HWP15

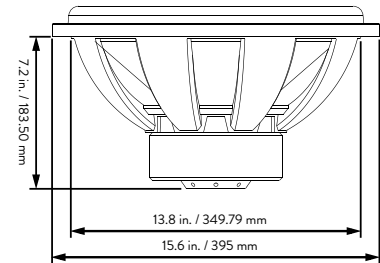

Recommended Air Space

Sealed 2.72 cu. ft. / Vented 2.99 cu. ft.

MODEL #	SUBWOOFER STRUCTURE	MAX POWER	NOMINAL POWER	IMPEDENCE	M CARTON
HWP8	8" / 20.3cm DVC Subwoofer	1000 Watts	500 Watts	Dual 4Ω Voice Coil	2
HWP10	10" / 25.4cm DVC Subwoofer	2000 Watts	1000 Watts	Dual 4Ω Voice Coil	2
HWP12	12" / 30.4cm DVC Subwoofer	2000 Watts	1000 Watts	Dual 4Ω Voice Coil	2
HWP15	15" / 38.1cm DVC Subwoofer	2000 Watts	1000 Watts	Dual 4Ω Voice Coil	1

■ **HW12D4**
12" 4 Ω DVC SUBWOOFER

1500
WATTS



IMPP Cone



High Temperature
Voice Coil

Works in Sealed or
Vented Enclosures



Recommended Air Space
Sealed 1.15 cu. ft. / Vented 1.42 cu. ft.

FEATURES:

- 2.0" / 5.8mm KSV Voice Coil
- PP Cone W/ Foam Surround
- Injection Molded PP Dust Cap
- High Energy Strontium Ferrite Magnet
- Convection Vented Monolithic Forged Yoke
- Electro-Plated Finished Top and Bumped Bottom Plate
- CAD Optimized Electro Mechanical and Magnetic Design
- Low Stress Connecting Leads
- Poly-Cotton Spider
- Fast On Speaker Terminals

MODEL #	STRUCTURE	MAX POWER	NOMINAL POWER	IMPEDANCE	M. CARTON
HW12D4	12" / 30.48cm DVC Subwoofer	1500 W	300 W	4Ω	2

Auto for Mind, Body & Soul

900 WATTS



Inverted IMPP Dome

Ribbed Foam Surround

Efficient Power Design

FEATURES:

- 1.5" / 3.81cm KSV Voice Coil
- PP Cone W/ Foam Surround
- Injection Molded PP Dust Cap
- High Energy Strontium Ferrite Magnet
- Convection Vented Monolithic Forged Yoke
- Electro-Plated Finished Top and Bumped Bottom Plate
- CAD Optimized Electro Mechanical and Magnetic Design
- Low Stress Connecting Leads
- Poly-Cotton Spider
- Fast On Speaker Terminals

HEW12 12" 4 Ω SVC SUBWOOFER

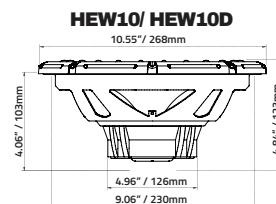

Recommended Air Space
Sealed 1.0 cu. ft. / Vented 1.37 cu. ft.

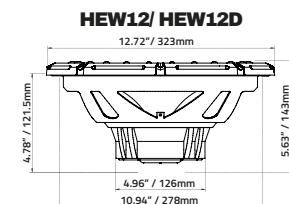

Recommended Air Space
Sealed 1.25 cu. ft. / Vented 1.68 cu. ft.

MODEL #	SUBWOOFER STRUCTURE	MAX POWER	NOMINAL POWER	IMPEDENCE	M CARTON
HEW10	10" / 25.4cm SVC Subwoofer	900 Watts	150 Watts	Single 4Ω Voice Coil	4
HEW12	12" / 30.48cm SVC Subwoofer	900 Watts	150 Watts	Single 4Ω Voice Coil	4
HEW12D	12" / 30.48cm DVC Subwoofer	900 Watts	150 Watts	Dual 4Ω Voice Coil	4

■ **HPR065K**
6.5" PRO AUDIO COMPONENT KIT

350
WATTS

FEATURES:

- Ultra High Efficiency Pro Audio 6.5"/16.51cm Component
- Shallow Mount Application
- Multi Application Use
- Paper Cone with Cloth Edge Accordion Surround
- Custom Embossed Protective Grills Included
- 1.5" / 3.81cm High Temperature Voice Coil
- Stamped Steel Basket

High Efficiency Design



Passive Crossover

Weather Treated Paper Cone

HM65PRO4 - MIDRANGE

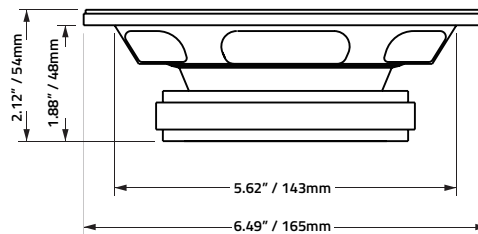

HT3PRO - TWEETER

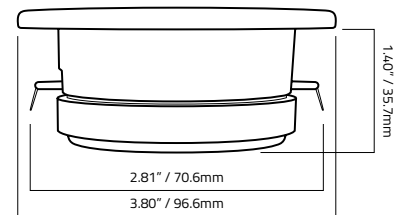

MODEL #	STRUCTURE	MAX POWER	NOMINAL POWER	IMPEDANCE	FREQUENCY RESPONSE	M. CARTON
HPR065K	6.5" / 16.51cm Component	350 Watts	175 Watts	4Ω	88hz - 18khz Hz	4

Audio for Mind, Body & Soul

■ HM65PRO4 6.5" PRO AUDIO SPEAKER

■ HM8PRO4 8" PRO AUDIO SPEAKER

Shallow Mounting

Weather Treated Paper Cone



FEATURES:

- Ultra High Efficiency Pro Audio Speaker
- Shallow Mount Application
- Multi Application Use
- Paper Cone with Cloth Edge Accordion Surround
- Custom Embossed Protective Grills Included
- 1.5" / 3.81cm High Temperature Voice Coil
- Stamped Steel Basket

**SOLD IN
PAIRS**

MODEL #	STRUCTURE	MAX POWER	NOMINAL POWER	IMPEDANCE	FREQUENCY RESPONSE	M. CARTON
HM65PRO4	6.5" / 16.51cm Pro Midrange	250 Watts	150 Watts	4Ω	45Hz - 25KHZ	6
HM8PRO4	8" / 20.3cm Pro Midrange	300 Watts	175 Watts	4Ω	45Hz - 25KHZ	4

■ HT3PRO 3" PRO TWEETER

Die-Cast
Aluminum Chassis

**300
WATTS**

FEATURES:

- Aluminum Diaphragm
- 1" / 2.54cm Voice Coil Diameter
- 5.4 oz Magnet
- Shallow Mount Application
- 101 dB Sensitivity
- Direct Connect Speaker Terminals
- Die-cast Aluminum Construction
- 1 Pair



High Output
Aluminum Dome

**SOLD IN
PAIRS**

MODEL #	STRUCTURE	MAX POWER	NOMINAL POWER	IMPEDANCE	FREQUENCY RESPONSE	M. CARTON
HT3PRO	3" / 7.62cm Pro Tweeter	300 Watts	150 Watts	4Ω	2k - 20k Hz	12

Auto for Mind, Body & Soul

Auto for Mind, Body & Soul



■ **HS3 1T**
1" Aluminum Dome Tweeter



■ **HS3 35**
3.5" 2-Way Speakers



■ **HS3 46**
4X6" 2-Way Speakers



■ **HS3 40**
4" 2-Way Speakers
Includes Grill



■ **HS3 50**
5.25" 2-Way Speakers
Includes Grill



■ **HS3 60** 6.5" 2-Way Speakers
Includes Grill

MODEL #	STRUCTURE	MAX POWER	NOMINAL POWER	IMPEDANCE	FREQUENCY RESPONSE	M. CARTON
HS3 1T	1" Aluminum Dome Tweeters	150 Watts	50 Watts	4Ω	-	24
HS3 35	3.5" 2 - Way Speakers	75 Watts	35 Watts	4Ω	75Hz - 35KHZ	12
HS3 40	4" 2 - Way Speakers	80 Watts	40 Watts	4Ω	75Hz - 20 KHz	10
HS3 46	4 x 6" 2-Way Speakers	80 Watts	40 Watts	4Ω	65Hz - 20KHZ	12
HS3 50	5.25" 2- Way Speakers	90 Watts	45 Watts	4Ω	55Hz - 20 KHz	10
HS3 60	6.5" 2- Way Speakers	150 Watts	50 Watts	4Ω	35Hz - 20 KHz	8

■ HS3 SERIES

FEATURES:

- 2 Way Speaker
- PEI Dome Tweeter
- Polypropylene Cone
- Rubber Surround
- High Temperature Voice Coil
- Rigid Stamp Steel Basket

■ HS3 65C

6.5" Component Speakers



Includes Grill



Aluminum Dome Tweeter



■ HS3 57

5x7" 2-Way Speakers

■ HS3 69

6 x 9" 3-Way Speakers

Includes Grill



MODEL #	STRUCTURE	MAX POWER	NOMINAL POWER	IMPEDANCE	FREQUENCY RESPONSE	M. CARTON
HS3 57	5 x 7" 2 - Way Speakers	125 Watts	55 Watts	4Ω	40 Hz - 20KHZ	10
HS3 65C	6.5" Component Speakers	175 Watts	75 Watts	4Ω	40 Hz - 20KHZ	6
HS3 69	6 x 9" 3 - Way Speakers	150 Watts	75 Watts	4Ω	40 Hz - 20KHZ	4

Auto for Mind, Body & Soul

Auto for Mind, Body & Soul



■ **HYS35**
3.5" Coaxial



■ **HYS40**
4" Coaxial



■ **HYS46**
4x6" Coaxial



■ **HYS50**
5.25" Coaxial



■ **HYS57**
5x7" Coaxial

MODEL #	STRUCTURE	MAX POWER	NOMINAL POWER	IMPEDANCE	FREQUENCY RESPONSE	M. CARTON
HYS35	3.5" / 8.89cm Coaxial	200 Watts	35 Watts	4Ω	75Hz - 25KHZ	12
HYS40	4" / 10.16cm Coaxial	250 Watts	40 Watts	4Ω	50Hz - 25 KHz	12
HYS46	4x6" / 10.16cm x 15.24cm Coaxial	250 Watts	40 Watts	4Ω	75Hz - 25KHZ	12
HYS50	5.25" / 13.33cm Coaxial	500 Watts	50 Watts	4Ω	50Hz - 25 KHz	12
HYS57	5X7" / 12.7cm x 17.78cm Coaxial	350 Watts	60 Watts	4Ω	45Hz - 25 KHz	10

- **HYS69G**
6X9" 4-Way
Includes Grill



- **HYS60**
6.5" 2 Way Speaker
**Does Not Include Grill*

■ HYS SERIES

FEATURES:

- Coaxial Speaker
- Mylar Dome Tweeter
- Polypropylene Cone
- Rubber Surround
- Rigid Stamp Steel Basket

Includes Grill

- **HYS60G**
6.5" 2 Way Speaker



MODEL #	STRUCTURE	MAX POWER	NOMINAL POWER	IMPEDANCE	FREQUENCY RESPONSE	M. CARTON
HYS69G	6x9" / 137.16cm 4-Way Speaker	400 Watts	75 Watts	4Ω	35 Hz - 28kHz	4
HYS60	6.5" / 16.51 cm 2 Way Speaker	350 Watts	60 Watts	4Ω	45 Hz - 25kHz	8
HYS60G	6.5" / 16.51 cm 2 Way Speaker	350 Watts	60 Watts	4Ω	45 Hz - 25kHz	8

**NEW
PRODUCT**

■ **HS1 65C
6.5" COMPONENT KIT**



Auto for Mind, Body & Soul

■ HS1 65C 6.5" COMPONENT KIT

FEATURES:

- 150 Watts Dynamic Power
- 65 Watts Nominal Power
- PEI Tweeter
- Polypropylene Cone
- Foam Surround
- 1" High Temperature Voice Coil
- Rigid Stamp Steel Basket
- Mesh Grill Included
- Frequency Response: 65Hz-20KHz
- Impedance: 4Ω

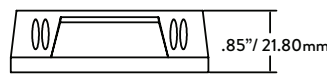
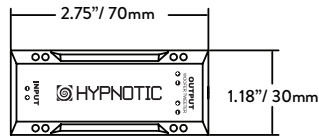
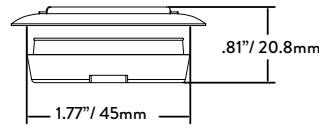
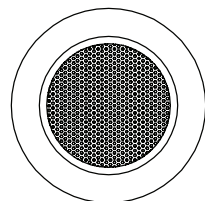
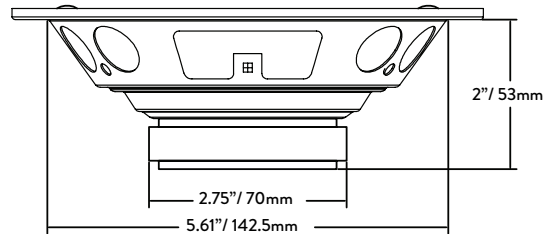
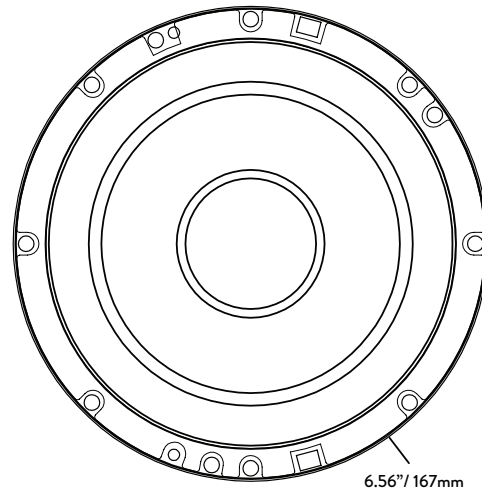

Auto for Mind, Body & Soul



■ HCKOANL

0 GA 100% COPPER
ANL AMP KIT

100% COPPER

KIT CONTENTS:

- 15' (4.6M) Gray / White 100% Copper Soft Touch RCA Cable
- 15' (4.6 M) 0 Ga. Red 100% Copper Soft Touch Power Cable
 - 15' (4.6M) 18 Ga. Blue 100% Copper Remote Wire
 - 17' (5.2M) 16 Ga. White / Gray Speaker Cable
- 2' (0.6M) 0 Ga. Gray 100% Copper Soft Touch Ground Cable
 - ANL Heat Resistant Fuse Holder
 - 150 Amp ANL Fuse
- Accessories : Wire Ties, Ring Terminals, Butt Connectors, Spades, Grommet & Split loom

MASTER CARTON: 6



100% COPPER



■ HCK4ANL 4 GA 100% COPPER ANL AMP KIT

KIT CONTENTS:

- 15' (4.6M) Gray / White 100% Copper Soft Touch RCA Cable
- 15' (4.6 M) 4 Ga. Red 100% Copper Soft Touch Power Cable
 - 15' (4.6M) 18 Ga. Blue 100% Copper Remote Wire
 - 17' (5.2M) 16 Ga. White / Gray Speaker Cable
- 2' (0.6M) 4 Ga. Gray 100% Copper Soft Touch Ground Cable
 - ANL Heat Resistant Fuse Holder
 - 60 Amp ANL Fuse
- Accessories : Wire Ties, Ring Terminals, Butt Connectors, Spades, Grommet & Split loom

MASTER CARTON: 8



■ HCK8MANL 8 GA 100% COPPER MINI ANL AMP KIT

KIT CONTENTS:

- 15' (4.6M) Gray / White 100% Copper Soft Touch RCA Cable
- 15' (4.6M) 8 Ga. Red 100% Copper Soft Touch Power Cable
- 15' (4.6M) 18 Ga. Blue 100% Copper Remote Wire
- 17' (5.2M) 16 Ga. White / Gray Speaker Cable
- 2' (0.6M) 8 Ga. Gray 100% Copper Soft Touch Ground Cable
- Mini ANL Heat Resistant Fuse Holder
- 30 Amp Mini ANL fuse
- Accessories : Wire Ties, Ring Terminals, Butt Connectors, Spades, Grommet & Split loom

MASTER CARTON: 12



Auto for Mind, Body & Soul

■ HKOANL 0 GAUGE ANL AMP KIT

KIT CONTENTS:

- 15' (4.6M) Gray/White Soft Touch RCA Cable
- 15' (4.6M) 0 Ga. Blue Soft Touch Power Cable
- 15' (4.6M) 18 Ga. Blue Remote Wire
- 17' (5.2M) 16 Ga. White/Dark Gray Speaker Cable
- 2' (0.6M) 0 Ga. Dark Gray Soft Touch Ground Cable
- ANL Heat Resistant Fuse Holder
- 150 Amp ANL fuse
- Accessories : Wire Ties, Ring Terminals, Butt Connectors, Spades, Split loom & Grommet

MASTER CARTON: 6



■ HK4ANL 4 GAUGE ANL AMP KIT

KIT CONTENTS:

- 15' (4.6M) Gray/White Soft Touch RCA Cable
- 15' (4.6M) 4 Ga. Blue Soft Touch Power Cable
- 15' (4.6M) 18 Ga. Blue Remote Wire
- 17' (5.2M) 16 Ga. White/Dark Gray Speaker Cable
- 2' (0.6M) 4 Ga. Dark Gray Soft Touch Ground Cable
- ANL Heat Resistant Fuse Holder
- 60 Amp ANL fuse
- Accessories : Wire Ties, Ring Terminals, Butt Connectors, Spades, Split loom & Grommet.

MASTER CARTON: 8



Auto for Mind, Body & Soul

■ HK4AGU 4 GAUGE AGU AMP KIT

KIT CONTENTS:

- 15' (4.6M) Gray/White Soft Touch RCA Cable
- 15' (4.6M) 4 Ga. Blue Soft Touch Power Cable
 - 15' (4.6M) 18 Ga. Blue Remote Wire
- 17' (5.2M) 16 Ga. White/Dark Gray Speaker Cable
- 2' (0.6M) 4 Ga. Dark Gray Soft Touch Ground Cable
 - AGU Heat Resistant Fuse Holder
 - 60 Amp AGU Fuse
- Accessories : Wire Ties, Ring Terminals, Butt Connectors, Spades, Split Loom & Grommet.

MASTER CARTON: 8



■ HK8AGU 8 GAUGE AGU AMP KIT

KIT CONTENTS:

- 15' (4.6M) Gray/White Soft Touch RCA Cable
- 15' (4.6M) 8 Ga. Blue Soft Touch Power Cable
- 15' (4.6M) 18 Ga. Blue Remote Wire
- 17' (5.2M) 16 Ga. White/Dark Gray Speaker Cable
- 2' (0.6M) 8 Ga. Dark Gray Soft Touch Ground Cable
- AGU Heat Resistant Fuse Holder
- 30 Amp AGU Fuse
- Accessories : Wire Ties, Ring Terminals, Butt Connectors, Spades, Split loom & Grommet.

MASTER CARTON: 12



Auto for Mind, Body & Soul

■ HSX SERIES PREMIUM RCA CABLES



MODEL #	LENGTH	M CARTON
HSX1.5	1.5' (0.45m)	200
HSX3	3' (0.9m)	200
HSX6	6' (1.82m)	100
HSX9	9' (2.74m)	50
HSX12	12' (3.65m)	50
HSX15	15' (4.5m)	50
HSX17	17' (5.1m)	50
HSX20	20' (6m)	50
HSXY2M	Y ADAPTER 2M / 1F	200
HSXY2F	Y ADAPTER 2F / 1M	200

FEATURES:

- Signal Transfer System with OFC twisted center conductors
- Translucent Red/Black Soft-Touch dual conductor Exterior Jacket
- Proprietary molded Grip design with gold metal pin
- High Strand Count Copper conductor
- Excellent Audio accuracy and performance

■ HXL SERIES HIGH PERFORMANCE RCA CABLES

MODEL #	LENGTH	M CARTON
HXL1.5	1.5' (0.45m)	250
HXL3	3' (0.9m)	200
HXL6	6' (1.82m)	200
HXL 9	9' (2.74m)	200
HXL12	12' (3.65m)	100
HXL15	15' (4.5m)	100
HXL17	17' (5.1m)	80
HXL20	20' (6m)	50
HXL Y2M	Y ADAPTER 2M / 1F	500
HXL Y2F	Y ADAPTER 2F / 1M	500

FEATURES:

- High Performance Jacket RCA
- Shielded with Gold Plated Tips
- Enhanced Signal Quality



Audio for Mind, Body & Soul

■ **HPWSERIES**
PREMIUM POWER WIRE



Auto for Mind, Body & Soul

MODEL #	COLOR	GAUGE	LENGTH	M. CARTON
HPW0R50	RED	0	ROLL 50' / 15.24m	2
HPW4R100	RED	4	ROLL 100' / 30.48m	2
HPW8R250	RED	8	ROLL 250' / 76.2m	2

■ HSWSERIES

PREMIUM SPEAKER WIRE



2 COLOR COMBINATION

RED / BLACK



MODEL #	COLOR	GAUGE	LENGTH	M. CARTON
HSW10G100	RED/BLACK	10	ROLL 100' / 30.48m	8
HSW12G250	RED/BLACK	12	ROLL 250' / 76.2m	4
HSW16G500	RED/BLACK	16	ROLL 500' / 152.4m	2
HSW18G1000	RED/BLACK	18	ROLL 1000' / 304.8m	2

Audio for Mind, Body & Soul



■ HHLC5R

HI-LOW LEVEL CONVERTER
WITH REMOTE TRIGGER OUTPUT

FEATURES:

- 2 Channel RCA Stereo Input Capacity
- 30 Watt High level Input Capacity
- Individual Input Gain Controls Remote Trigger Output

MASTER CARTON: 100

■ HCAP2KF

HIGH PERFORMANCE
CAPACITOR



FEATURES:

- 2000 Watts
- 2 Farad Capacitance (-10% + 50%)
- 20 Volts Max Operating Volts
- 85° Degrees C-Max Operating Temperature
- Blue Digital Voltage Display with 2 LED'S
- Includes Mounting Bracket and Charging Bulb

MASTER CARTON: 12

Auto for Mind, Body & Soul



HYPNOTIC™

Audio for Mind, Body & Soul

www.hypnoticusa.com



302 Hanmore Industrial Parkway
Harlingen, TX 78550
Toll Free: (877) 787-0101 / Fax: (956) 421-4513
sales@dbdrive.net / Tech Support: support@dbdrive.net

HYPCAT23A
81153603 777

Printed in China